

Dummies guide to aircraft antennas

Probably the single biggest issue that we encounter with the installation of our XCOM radios by customers in the field is poor antenna performance. Most customers are simply unaware that a poor antenna can affect their radio performance substantially and they mistakenly expect that any antenna pulled out of the box will work perfectly on their aircraft.

The following information has been amalgamated from a number of reliable sources (credited on the last page) and assembled into this easy-to-use reference. We have attempted to decipher the technical jargon into plain English for the average XCOM owner.

Some people believe, as I used to, that installing and tuning antennas on aircraft is akin to some sort of witchcraft but, with the help of some simple basic guidelines, it is possible to get the optimum performance from your aircraft antenna with very little effort.

In this guide we try to demystify and explain items and concepts such as coax cables, types of antennas, the SWR or VSWR reading, best location, grounding of the antenna, ground planes and much more. After reading this document you certainly won't be an expert but you should have a much clearer understanding of the different requirements applicable to aircraft antennas.

Many people also refer to antennas as aerials however we stick to the more correct term, antenna, throughout this manual. The terms Comm, Radio and VHF Transceiver all refer to the aircraft communications transceiver which operates across the VHF aircraft frequency band of 118.000 to 136.975 MHz.

Ground Rules - **WARNING!**.... Just so you know...

- DO NOT transmit without an antenna fitted which is specifically designed for air-band frequencies (118.000 – 136.975 MHz).
- DO NOT transmit with a damaged coax cable.
- DO NOT transmit with a disconnected coax cable
- DO NOT transmit when the antenna is grossly out of tune i.e. SWR greater than 3:1

All of the above situations may cause the reflected power, normally sent out through the antenna, to severely damage the radio.

What are Wavelengths, Frequency, Bandwidth and Ground Planes ?

The wavelength is the distance between peaks or troughs within a single oscillation of a transmission. Sounds complex doesn't it – it's not really. Imagine a wave moving across the water. As each wave hits the shore, the water rises and falls. These are the peaks and troughs. A radio signal travels in the same way and the wavelength is simply the distance between two consecutive peaks or troughs.

You are probably aware of the term frequency and how it relates to your use of the radio but what is it really? Frequency is simply the number of waves emitted per second. A frequency of 118.000 Megahertz (MHz) means that 118 million waves are emitted each second. Now, if more waves are emitted each second, then they must be closer together. So this means that the higher the frequency, the shorter the wavelength. Simple huh?

Without going into the complex mathematics and speed of sound, etc, believe me when I say that for a frequency of 144 MHz the wavelength is approximately 2 metres, hence the name 2M band. The wavelength for the aircraft band, from 118.000 MHz to 136.975 MHz, is slightly longer than this at approximately 2.2M.

The bandwidth is associated with the frequency range of operation and, put simply, is the difference between the highest frequency and lowest frequency within the band. The general aircraft frequency range is from 118.000 MHz to 136.975 MHz so the bandwidth is 18.975 MHz.

Ground planes are simply the 'grounded' side of the antenna. A signal is radiated by the antenna by generating a difference in potential between the antenna and an 'earth'. Take a battery for example. If you connect a wire from one side of the battery to a bulb, you get nothing. But if you connect wires from both sides of the battery to the bulb you get – that's right – light. Why ? Because the bulb is converting the potential difference between the positive (+) and negative (-) terminals into light.

Antennas work in a similar way – you must have a positive and negative terminal. The negative terminal is called the earth, ground or ground plane. All antennas require a ground plane of one sort or another. Some use the aircraft skin (on metal aircraft), some use a foil or aluminium sheet inside the aircraft, some use a coil of wire built into the base of the antenna and others use wires radiating from the base of the antenna.

Polarisation

Polarisation simply refers to the orientation of the signal being transmitted. A vertical antenna radiates a vertically polarized signal and a horizontal antenna radiates a horizontally polarized signal.

VSWR or SWR

Voltage Standing Wave Ratio (VSWR), or SWR for short, of an antenna is a measure of how efficiently your radio is radiating the energy it produces when you transmit. It is represented as a ratio and is generically; all though not accurately, referred to as the ratio of emitted power to reflected power within an antenna. There are many good reference books on the subject if you want to know more.

You don't need to know what it actually is in order to measure it; you just need an SWR meter or an Avionics shop that can help you with three simple readings.

Choosing the right antenna for your aircraft

There are a number of different types of antennas available to suit your aircraft. Some are expensive, some are cheap, some are designed to be used externally and others are designed to be used internally (that means inside the aircraft structure, not inside you!)

I can only pass on information about the actual antennas which I have used. There are hundreds of new versions out there on the market with many different features but they are generally broken up into the following major groups.

Fibreglass or stainless steel whip antennas – these are generally cheaper $\frac{1}{4}$ wave antennas most suited to Ultralight aircraft, sport aircraft, etc.



Fibreglass rigid antennas - more expensive $\frac{1}{4}$ wave antennas like the Comant 121 model which offer extremely good SWR readings (see below) across the entire aviation band and offer excellent performance.



Internal dipole antennas - antennas that have two $\frac{1}{4}$ wave 'poles' placed back to back. The most common dipole is the half wavelength dipole. These antennas use one pole as the ground plane and are generally installed vertically in composite aircraft like gliders. They will not work in metal aircraft.



Base station antennas - usually longer in length than standard $\frac{1}{4}$ wave antennas, most base station antennas are $\frac{1}{2}$ wavelengths being approximately 1.2 m long plus a base section. They are normally 'ground plane independent' (meaning that the ground plane is 'in-built') and are mounted vertically on towers or the side of buildings. They are of course not suitable for flying (unless you want to loose 30 knots).



Generally, a larger diameter antenna will give you broader band performance. That is, an antenna that is large in diameter or flat and wide like the internal dipoles will give you much better broadband performance than a thin stainless steel antenna. When a thin stainless steel antenna is tuned to 127 MHz (roughly the middle of the aircraft band) the maximum broadband performance it can give is around 5 MHz whereas larger diameter antennas can give broadband performance over 10 MHz range.

The following two graphs are a good indication of how a wider diameter antenna can generally provide better performance. The graph on the left-hand side shows a performance chart for a Mobile 1 base station antenna.

Reading the graph at 118 MHz shows a SWR of less than 1.6:1, at 126 MHz it is 1:1 and 136 MHz it is around 1.7:1 making this a fantastically performing antenna across the entire airband range.

The graph on the right however shows a stainless steel whip type antenna which is tuned to 124 MHz where it has a SWR reading is around 1.1:1 which is great. Unfortunately however at 129 MHz the antenna is already above our upper limit of 3:1 SWR and the same at the lower frequency of around 121 MHz. What this means is the stainless steel whip type antenna will perform really well at around 124 MHz but its performance drops off quickly when the radio is moved off this frequency. This antenna should not be used for any frequencies lower than 121 MHz or higher than 129 MHz because of the risk of radio damage.

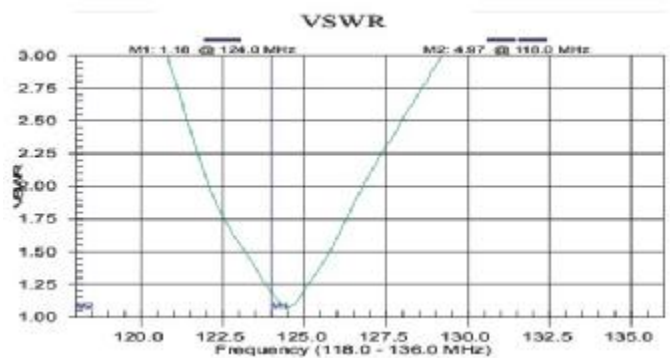
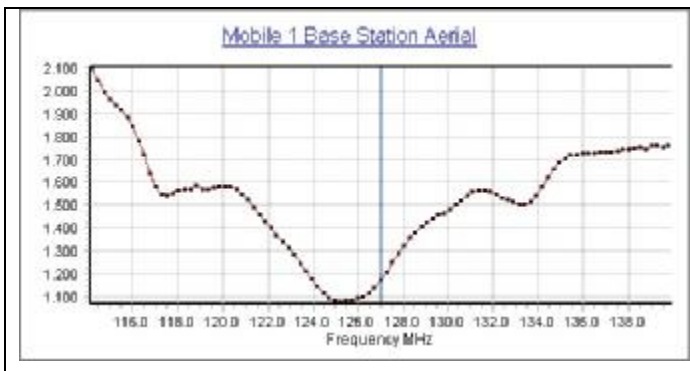

Coax cable

Spending thousands on a brand new radio is a waste of time if none of the signal can be transmitted for others to hear. Between the antenna jack on your radio and the antenna itself is a shielded cable commonly called coaxial cable or simply 'coax'. This cable provides a pathway for your transmission signal and needs to be perfect otherwise your installation is compromised before you start.

There are several types of coax cable. The most common coax cable is that used in television antenna installations which has a resistance, or impedance, of 72 Ω (Ohm).

Aircraft transceivers use 50 Ω coax. Both types of coax look similar to each other but the ONLY correct type of cable to use for an aircraft installation is 50 Ω . Be very careful with the type of coax you use as it can damage the radio if you have the wrong type.

You cannot use normal wire as a signal line to your antenna – you must use the appropriate coax cable.

Coax cable has an inner wire and an outer braid or shield (see diagrams below). The inner wire carries the signal to the antenna and the outer braid provides the potential difference mentioned earlier. The outer braid also 'earths', or suppresses, outside interference from degrading the signal.

Not all coax is created equal. Many of the chain electrical stores are now selling 50 Ω RG-58 coax cable which utilizes an aluminium foil as the shield instead of a wire braid. Whilst this may work in some installations it is our experience that as soon as the cable is crimped and bent the foil is damaged and becomes useless.

Only use good quality 50 Ω RG-58 coax supplied through an Avionics shop for your aircraft installation.

For many of our customers with unshielded ignition systems we also recommend RG-400 double shielded coax which has two shields and in most instances eliminates any ignition noise. RG-400 coax is also rated at 50 Ω and can be purchased at any good Avionics shop. You have to remember that once the coax is installed it generally lasts the life of your aircraft so skimping on a few dollars during installation does not make good sense. You should purchase the best quality coax that you can afford and ensure that it is the correct one for your avionics installation.

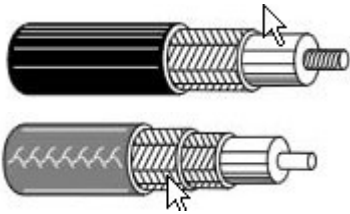

50 Ω RG-58 coax

50 Ω RG-400 double shielded coax

It is generally regarded across the industry that the best performance can be obtained by keeping the coax cable as short as possible. Do not coil the coax cable to create loops and do not run the VHF antenna coax alongside the transponder coax because of interference problems.

Connectors

When a coax cable needs to be connected to either an antenna or to the XCOM radio it's usually done with a BNC connector. A BNC connector is light, mechanically strong and reasonably weatherproof. It makes an ideal fitting for connecting your coax to the antenna and radio. BNC connectors are available in several types, the most popular being the crimped connection followed by a soldered connection.

My experience has shown that most people use too much heat when soldering and this can actually damage both the plug and the cable. As a result we suggest using a crimped connection.

Crimped connections need to be performed with a special crimping tool which is quite expensive. (shown right >>)

For most customers this is a simple job done by your local Avionics shop who can also supply you with a finished cable at reasonable cost.

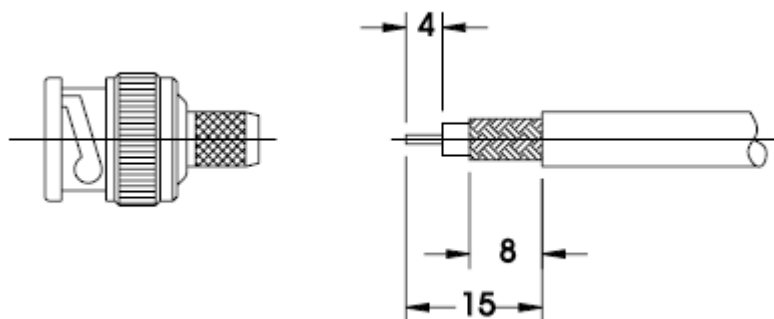

Dimensions in millimeters

How to prepare and crimp a coax cable

STEP 1

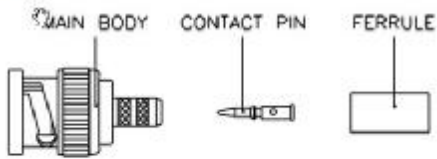

Crimped connections are very reliable and strong offering years of service in the field.

Step 1. Layout all of the parts required for a crimped connection.

STEP 2



Step 2. Strip back the outer cable shield to expose the braid and also strip back the centre shield to expose the cable core.

STEP 3



Step 3. Slide the ferrule over the cable and position the contact pin and then crimp the contact pin in place.

STEP 4

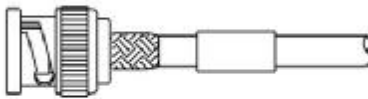

Step 4. Insert the cable into the rear of the BNC connector until you hear the contact pin click into position.

STEP 5

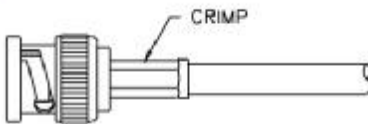

Step 5. Finally, slide the ferrule down the cable until it is firmly seated on the base of the BNC and crimp into position using an approved crimping tool.

Many avionic shops will do this crimping for you while you wait for a nominal charge.

Finally, check the coax cable and BNC fittings for continuity to make sure the connection has been completed correctly.

Well, that's it. We have completed the coax connection between the radio and the antenna.

Checking the SWR

Every antenna installation in an aircraft regardless of the quality of the antenna needs to be checked with a SWR meter before first flight.

Here is what you need to know, some basic facts:

- The scale on an SWR meter reads from 1 to infinity.
- The smaller the number, the better the SWR reading and the better your antenna will perform.
- The scale is not linear, it is logarithmic. From 1 to 3 covers more than half of the scale on a SWR meter. The remainder covers 3 to infinity!
- A SWR reading of more than 3 may be hazardous to your radio. (Often marked in red on the scale). Because of the logarithmic scale, you don't have to be far into the red before you are into the big numbers!
- For any given frequency there is a corresponding wavelength and one ideal length of antenna.

- Because we are changing frequencies often, it stands to reason that the actual length of our antenna has to be a compromise since we can't keep changing the length of the antenna every time we change frequency. The airband covers a very wide range from 118.000 MHz up to 136.975 MHz
- Most aircraft antennas are tuned in the middle of the airband frequency (usually 127 MHz).
- The ideal number to aim for on the SWR meter is 1:1 (pronounced 1 to 1) but this is rarely achieved. This means all the energy is being radiated and none being 'reflected' back into the radio. A SWR of 2:1 or less is OK. Less than 1.5:1 is very good, more than 3:1 will damage most radios. It is generally regarded that a SWR reading of less than 2.5:1 is acceptable for aviation use but the intention is to get the SWR as low as possible.
- In practice the size and shape of the antenna's ground plane can affect the SWR of an antenna. (no ground plane = high SWR)
- ATC radio transmissions are vertically polarised. This means that your aircraft antenna should be more vertical than horizontal when mounted for best performance.

How to use the SWR meter

Connect the antenna BNC plug to the side of the SWR meter marked antenna.

Connect the radio to the side of the SWR meter marked transmitter.

In other words the SWR meter is connected between the radio and the antenna.



Rig the aircraft and move it well away from hangars (and hangers-on for that matter). SWR'ing inside a hanger is a complete waste of time because the meter will measure the signal bouncing off the metal from the hangar and give a high reading!

Firstly, set the first frequency to 118.000 and calibrate the SWR meter by doing a brief transmission* and adjust the power needle to the 'set' position (100% full scale deflection) using the knob on the front of the meter.

If you have the most common SWR meter which is a single dial meter you will have to switch between calibrate and SWR operations and note the readings.

*Note: You don't need to talk to anyone; in fact you don't even need your headset plugged in. You are just measuring the efficiency of the 'carrier wave' not the modulation (voice signal).

Then repeat the operation above on 127.000 MHz and again on 136.975 MHz. This will give us three SWR readings across the entire aircraft band. One reading is at 118.000 MHz, the second reading at 127.000 MHz and a final reading at 136.975 MHz.

A typical example SWR reading follows...

118.000 = 2.3:1

127.000 = 1.5:1

136.975 = 2.8:1

From these three readings we can see that the antenna is best at 127 MHz, it is not too bad at 118 MHz but the SWR readings get high at 136 MHz. This tells you that the antenna is going to perform better in the central and lower frequencies than it is at the top of the frequency range. In this example the antenna is not perfect especially at 136 MHz but it will do the job. Ideally we would like to get a better reading and to do this you tune your antenna.

How to tune the antenna

Many of the more expensive antennas come pre-tuned and it is pretty much impossible to make changes to the antenna. Some of the cheaper antennas however have the ability and the requirement to be tuned in each installation.

Screw the antenna onto the antenna base as far as it will go. Note the SWR readings at the three frequencies above.

As we mentioned earlier, the higher the frequency, the shorter the antenna. You should try to adjust towards the frequency with the higher SWR, so in the previous example we need to adjust towards the higher frequency (136.975). This means we need a shorter antenna so we can trim one or two millimeters off the top of the antenna and recheck the SWR.

If the SWR is higher on the lower frequency, then (the lower the frequency the longer the antenna) we need to lengthen the antenna.

Take care. It may not be possible to get 'flat line' in all cases. If the SWR reading starts to increase again before reaching 1:1 then you have gone too far, so stop cutting.

To get a correct readings keep people and metallic items away from the antenna.

When you you've got the best SWR reading you can, remove the meter and reconnect the coax directly to the radio, Go for a fly and get a proper radio check.

Important notes on antenna tuning

If your antenna is supplied over-size it will be grossly out of tune and you will need to tune it.

If your ground plane is not making good electrical contact with the antenna base your antenna will be grossly out of tune.

Transmitting (more than 1-2 sec for test purposes) without an antenna connected or with an antenna grossly out of tune could damage the radio. The energy produced by the radio when in transmit mode needs to radiate (and hence dissipate heat). If it is unable to do so (for whatever reason) it will be reflected back into the radio and damage the PA (Power Amplifier) unit.

Other antenna information

- If your aircraft is fitted with two radios it is advisable to have the antenna for comm one on top of the aircraft and comm two on the bottom. Please make sure that the antennas are separated by at least 36 inches (or 1 meter).
- Nearly every antenna which we use in light aircraft will require a ground plane of some description.
- Ground the antenna to the aircraft in metal aircraft

The antenna can be grounded through the antenna mounting screws in metal aircraft however, it is important to obtain a good electrical bond where the antenna is mounted by ensuring the area is free of paint and debris. With many antennas a backing plate is placed in the aircraft interior with the antenna connected by mounting screws through the aircraft skin. The backing plate must obtain a good electrical ground to the aircraft skin by removing the paint. The electrical ground can be checked by placing a multi-meter between the antenna mounting screw and the aircraft skin. The reading should be no greater than 0.003 Ω

- Grounding the antenna in a composite aircraft

Composite aircraft create unique challenges when trying to ground the antenna and care must be taken to provide an adequate ground plane. For best performance the ground plane should be horizontal and have a radius of at least one quarter wavelength of the antennas operating frequency, or as large as practical. A good general rule to follow is to ensure the ground plane radius is at least equal to the antenna height.

- The location of an antenna on any aircraft is very important. VHF transmissions are line of sight and any object in the transmission path like the tail plane, other antennas, people or undercarriage (for antennas mounted on the bottom of the plane) will reduce the performance of your antenna. Antennas should not be mounted anywhere near the engine exhaust. In a perfect installation the antenna would be located on a flat surface centrally located in the middle of a ground plane. Unfortunately however this is not always possible and the best position must be a compromise for each individual aircraft type.

Well, that's it. You now have a little bit of knowledge about aircraft antennas, coax cables and how it all comes together when installed into your aircraft. If any of this is beyond your ability the best thing you can do is get your aircraft to your local Avionics shop and have them install the equipment and test it before sending you off into the blue yonder. The money you spend on getting a good radio installation is not a large part of the cost of your plane and for your safety you should never be without good communications.

Credits

- Jim Weir RST Engineering
- Mobile One Australia website
- Comant Industries website
- Phil Allen